

A dynamic approach to ‘simple’ algebraic curves

“Both didactic theory and practice of computer-assisted mathematics teaching always reflect the latest state of software development, which is considered the non plus ultra.”

Prof. Dr. Heinz Schumann
Faculty III, Mathematics/Informatics,
University of Education Weingarten

1. Introduction

In these days of reduced mathematical awareness – when mathematical education within context of international student assessments like PISA is focused on so-called “standards of mathematical education” and “core curricula”, – it may be questionable to propagate a mathematical topic which has seldom found its way into the curricula of school mathematics, although its treatment already has a long lasting methodical and didactic tradition.

The subject of “Algebraic Curves” should be re-evaluated for the purposes of general teaching projects, course work projects, working groups and extracurricular mathematics e.g. for gifted students in consideration of newly developed and adequate dynamic geometry computer tools. The arguments for the treatment of algebraic curves using computers in school geometry brought forward by Schumann 1991, Weth 1993, Schumann & Green 1994, Schupp & Dabrock 1995 and others still apply, and we shall repeat them here in brief.

The following points favour the treatment of algebraic curves:

- Algebraic curves bridge the gap between (synthetic) geometry and algebra
- they offer a variety of problems, solution strategies and relationships of mathematical interest
- they are of a generalising nature
- they support modelling activities
- they enhance functional and operative thinking
- they play an important role in the history of mathematics
- they are aesthetically pleasing.

Computer Algebra Systems and Dynamic Geometry Systems (DGS) are excellent exploration and reconstruction media for approaching the subject of algebraic curves. We shall therefore treat algebraic curves in context, using computer tools that are available in the classroom. These tools should be

menu-controlled as they are used only temporarily and by novices, therefore command-controlled tools will not be discussed here. Of course, sufficient mathematical knowledge is required for successful computer-assisted treatment of algebraic curves.

Generally speaking, algebraic curves are represented as follows:

An algebraic curve is the zero-set of a polynomial in x and y

$$\{(x, y) : \sum_{i=0}^k \sum_{j=0}^{\ell} a_{ij} x^i y^j = 0\}_{\mathbb{R} \times \mathbb{R}}$$

in which $a_{ij} \in \mathbb{R}$; $\max(i + j)$ with $a_{ij} \neq 0$ is the degree of the algebraic curve. This algebraic equation is an object of algebra while the corresponding graph is an object of synthetic geometry.

The following diagram (Schumann 2001) will serve to illustrate the options of representation and interaction using the computer tools currently available:

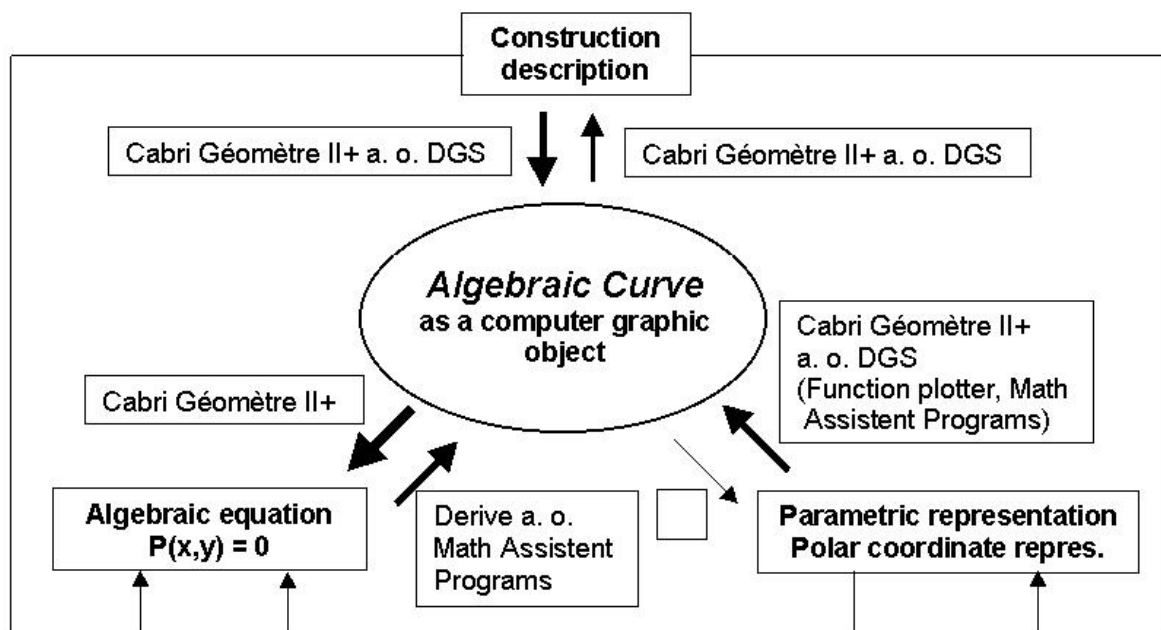

Diagram

↓ : “Classical” algebraic curves are constructed with compass and ruler; the constructions generally have no more than two parameters defining shape and position. Dynamic Geometry systems (DGS) can illustrate the point-by-point generation using the trace mode, which supports the point-set interpretation of curves (see, e.g. Schumann 1991). Dynamic variation of parameter values (e.g. for investigating various cases and for generating families of curves) requires that one must be able to generate them as referenceable graphic objects not only

as states of the screen. The corresponding graph is generated by dynamic interpolation of supporting points (with rounded coordinates depending on the system arithmetics).

These curves may be constructed by different methods, e.g. as foot curves, slide point curves, cissoids, conchoids, rolling curves, image curves at specific transformations etc. Constructions of curves as envelopes will not be considered here.

↑ : The option “Repeat Construction” will give us the construction method for any of the constructed curves.

↙ : Cabri Géomètre II+ (www.cabri.com) is the only DGS among those available on the market, that bridges the gap to algebra by determining the representation of an algebraic curve as the zero-set of a polynomial in x and y with correspondence to a selected coordinate system. For this, Cabri Géomètre II+ uses a numeric algorithm which provides satisfactory results for algebraic curves

$P(x, y) = \sum_{i=0}^k \sum_{j=0}^{\ell} a_{ij} x^i y^j = 0$ up to the 6th degree. (Roughly,

the algorithm can be described as follows: Random selection of about 100 supporting points of the generated curve; calculation of the $\frac{(n+1)(n+2)}{2}$

coefficients of $P(x, y) = 0$ of degree n using a suitable system of equations derived from the point coordinates starting with $n = 1$ until the rest of the selected points approximately issues zeros of $P(x, y) = 0$.)

↗ : Visual testing of the correctness of the resulting algebraic curve is possible using a mathematics software capable of plotting implicit functions. Among the menu-controlled software tools, DERIVE (derive-europe.com) offers this option.

↖ : It is possible to achieve a static graphic generation of an (algebraic) curve from a parametric or polar coordinate representation using suitable software systems or modules for plotting functions. Dynamic generation of graphic curve objects by DGS from these representations using direct manipulation for variation of running parameter values is much more impressive, because the user is able to observe the curve creation by trace mode individually applying slider techniques.

↘ : There is no (published) computer tool, as yet on the market, which generates the parametric or polar coordinate representation for an algebraic curve given as an adequate constructed computer graphic object. The

prototypic “paramGeo” Package (Roanes-Lozano et al. 2003) for MAPLE (maplesoft.com) or DERIVE is able to generate these representations).

This ends the summary of the general technical facilities of computer tools in as far as they are of relevance to this article.

The derivation of the algebraic equation $P(x, y) = 0$ from the synthetic-geometric construction of a curve is interesting and fruitful from the mathematical point of view because this derivation provides – independent of the experimental and inductive methods of knowledge finding – mathematical insight and argumentation for the algebraic equation produced by Cabri II+. In the case of algebraic curves of 2nd degree, so-called conic sections, an analytic-geometrical derivation of the algebraic equation could be achieved due to adequate constructions. That is not possible in general in the case of algebraic curves of higher degree; the derivation needs a parametric representation or a polar coordinate representation and elimination or substitution of the parameters from these representations may induce difficult calculation problems.

2. A method for the treatment of ‘simple’ algebraic curves

The following method combines geometry and algebra as well as inductive and deductive methods of knowledge acquisition or knowledge verification and requires only elementary mathematical knowledge.

We shall term an algebraic curve (AC) as “simple” in this context if integral construction parameters are inducing integral coefficients of the corresponding algebraic equation with regard to a suitable Cartesian coordinate system. Almost all the classical algebraic curves can be treated as simple curves.

- 1) **Construction** of the AC with a DGS (here: Cabri II+) according to instructions and phenomenological description.
- 2) **Variation** of the construction parameter values in order to observe and describe the changes in position and shape of the AC. If helpful, generation of an animated graph.
- 3) **Embedding** the constructed AC in a suitable Cartesian coordinate system.
- 4) **Automatic determination of the algebraic equation** $P(x, y) = 0$ of the AC with respect to the chosen coordinate system and testing the equation.
- 5) **Linkage** of the construction parameter objects to grid points of integer

coordinates and with grid snap for restriction to integral construction parameters.

6) **Experimental-inductive identification of the coefficients in $P(x, y) = 0$** and control of these coefficients as a function of the construction parameters. (Eventually inductive graphic verification of $P(x, y) = 0$ for non-integral parameters using a computer algebra system, e.g. DERIVE.)

7) **Mathematical verification of $P(x, y) = 0$**

Direct analytic-geometrical derivation of $P(x, y) = 0$ from the construction description of the curve or, if that is not possible: Derivation of the parametric or polar coordinate representation from the construction description; dynamic generation of the AC according to these representations for control; elimination or substitution of the running variables or parameters, also using a CAS (e.g. DERIVE).

3. Application of the method

In the following, this method will be applied to classical algebraic curves of the 3rd, 4th and 6th degree. Conic sections, which can be treated the same, will be left out. – Not all the instructions of the method will be explained in the following examples; the details of the computer software functions are not described.

Example 1 (Cissoid)

The cissoid lends its name to a whole class of algebraic curves, which are constructed with the same construction principle. It is used for example in the geometric solution of the Delian problem (duplication of the cube).

1) How to construct the curve:

- Construct a circle of diameter OA (construction parameter).
- Construct a tangent in A perpendicular to the diameter OA .
- Put one on the circle movable point K .
- Construct a ray with the initial point O through K which intersects the tangent in G .
- Lay off line segment KG from O on to this ray.

Which locus describes P , if K moves in a circle?

2) The resulting locus is the cissoid (Fig. 1.1), which is symmetric to OA and has a pointed end in O and the tangent as asymptote.

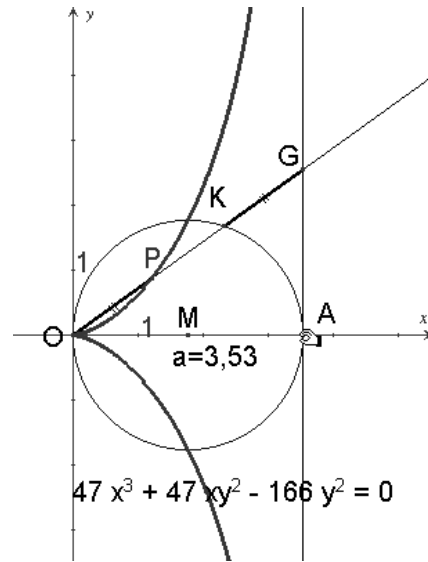
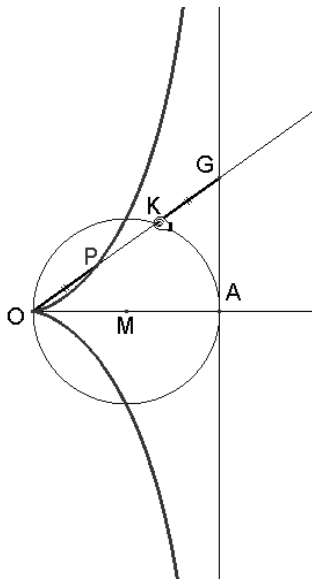

Fig. 1.1: A cissoid's construction Fig. 1.2: A suitable cissoid's embedding

3 & 4) Cabri II+ generates an algebraic equation of the third degree when we embed the curve in a Cartesian coordinate system (Fig. 1.2 with O as origin and with diameter OA on the positive x -axis). Because of its symmetry to the x -axis there are only y -terms with even exponents in the summands. We confirm experimentally the correctness of the equation with point testing (Fig. 1.3).

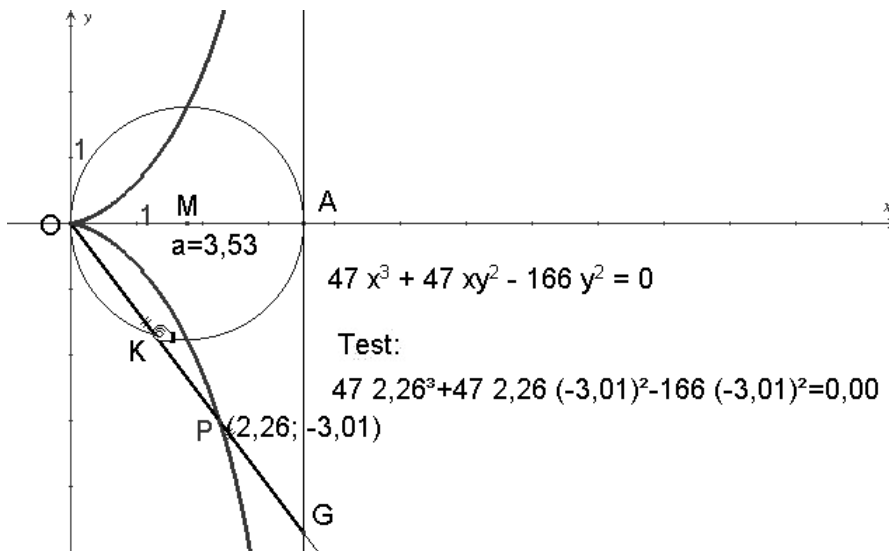

Fig. 1.3: Testing cissoid's equation

5 & 6) The dependences between parameter a and the coefficients of the equation could only be recognised when A is linked to the integral grid and the integral values of parameter a are varied (Figs. 1.4 & 1.5). Only coefficient of the y^2 -term depends on a ; it equals a and the resulting equation of the curve is:

$$x^3 + xy^2 - ay^2 = 0 \dots\dots\dots (1.0)$$

which can be confirmed by further variation of integral values of parameter a .

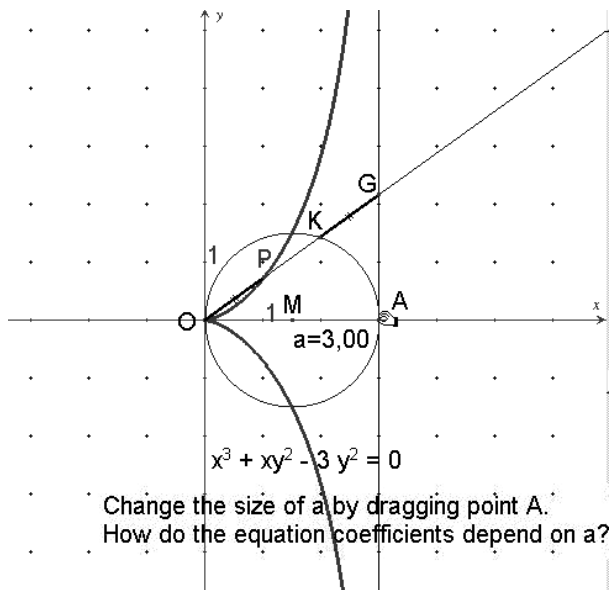

Fig. 1.4:
Investigating coefficient's dependency

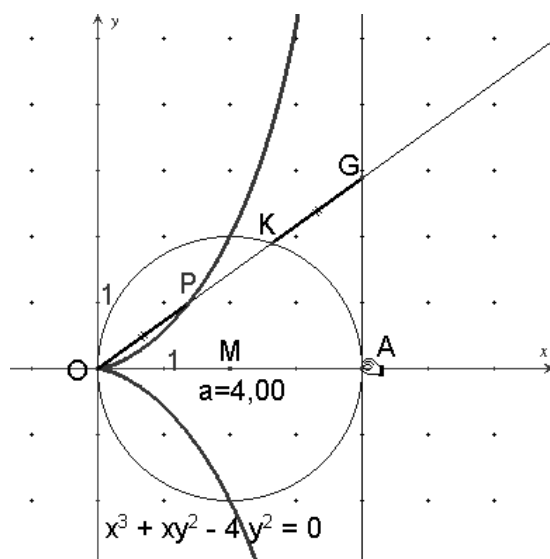

Fig. 1.5

We extrapolate the result for non-integral parameter values, e.g. by plotting curves of equation (1.0) with DERIVE (see the example in Fig. 1.6 for an approximate value of $a = \sqrt{10}$).

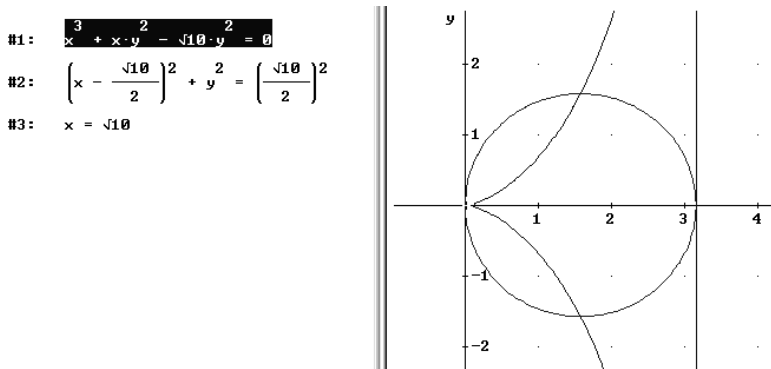

Fig. 1.6: Equation testing with DERIVE

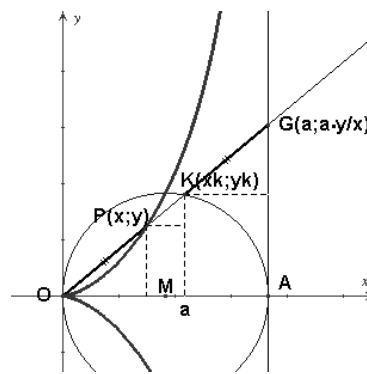

Fig. 1.7: Deriving the algebraic equation

7) Fig. 1.7 shows the analytic-geometrical derivation of the algebraic equation. Ray OG has the slope $\frac{y}{x}$ and, correspondingly, G has the coordinates $(a, \frac{ay}{x})$. After construction, P has the coordinates $x = a - x_k$ and $y = \frac{ay}{x} - y_k$, i.e. for $K : x_k = a - x$ and $y_k = \frac{ay}{x} - y$. Substitution in equation of the circle $(x - \frac{a}{2})^2 + y^2 = (\frac{a}{2})^2$ results in $(a - x)^2 + \frac{y^2}{x^2} (a - x)^2 - a(a - x) = 0$. Division by $a - x \neq 0$ ($x = a$ is not a point of the cissoid)

and multiplication with $x^2 \neq 0$ result in

$$x^3 + xy^2 - ay^2 = 0 .$$

Generalisation: We shall now generalise the cissoid into the so-called hypo-cissoid, by constructing the perpendicular AG on the positive x -axis in an arbitrary grid point. (Fig. 1.8). It is easily recognised that the corresponding two-parameter curve obeys the equation $x^3 + xy^2 + (d - a)x^2 - ay^2 = 0$, in which $(a - d)$ is the x -coordinate of the point of intersection of the curve with the x -axis. In case of $(d - a) > 0$, in Cabri the hypo-cissoid must be composed of two partial curves, which are created by K_1 resp. K_2 positioned on the circle arcs separated by the perpendicular line through A . (Fig. 1.9). The animated graph in Fig. 1.10 shows the different shapes of the hypo-cissoid for $0 \leq a \leq d_0$ and for $d_0 \leq a$ (in the case of $a = d_0$ the cissoid is clearly visible separating the curves with $(d_0 - a) > 0$ resp. $(d_0 - a) < 0$).

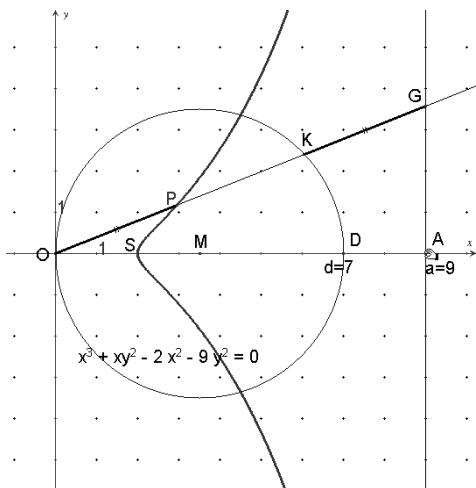

Fig. 1.8:

Hypo-cissoid, case $(d_0 - a) < 0$

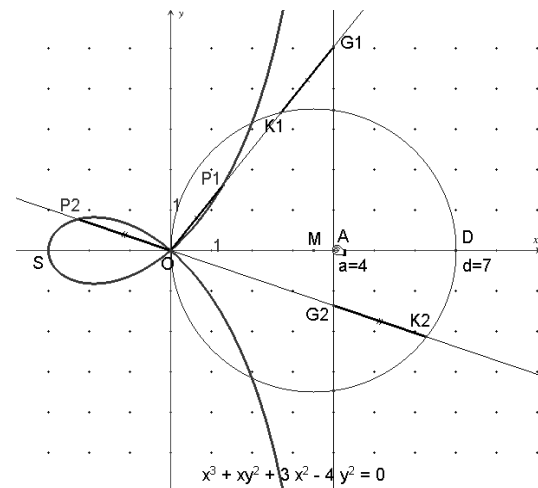

Fig. 1.9:

Hypo-cissoid, case $(d_0 - a) > 0$

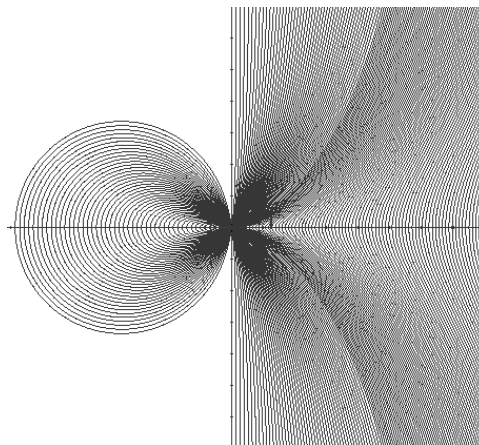

Fig. 1.10: Hypo-cissoid's animation for parameter a

Example 2 (Pascal’s limaçon – or Pascal’s snail)

Pascal’s limaçon is named after Stephan Pascal, the father of the famous Blaise Pascal. It can be constructed in several ways. We shall start with its construction as a foot curve (Fig. 2.1):

- Construct a circle with centre M through R and then a point P (pole), first positioned outside the circle, i.e. with $|PM| > |MR| = r$. Put a movable point B on the circle and construct the circle tangent in B .
- Drop the perpendicular from P to the circular tangent with foot F .

What is the locus of F if B circulates?

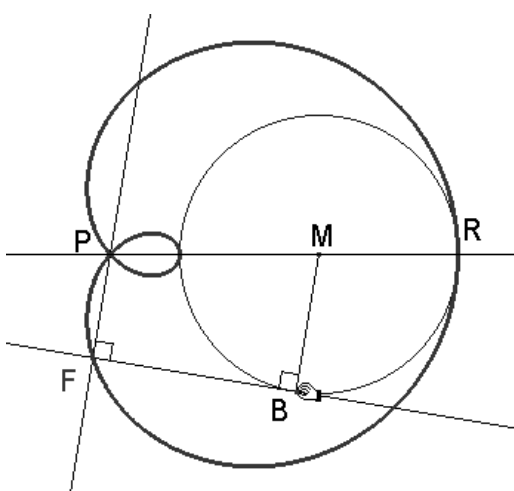

Fig 2.1:

A construction of Pascal’s limaçon

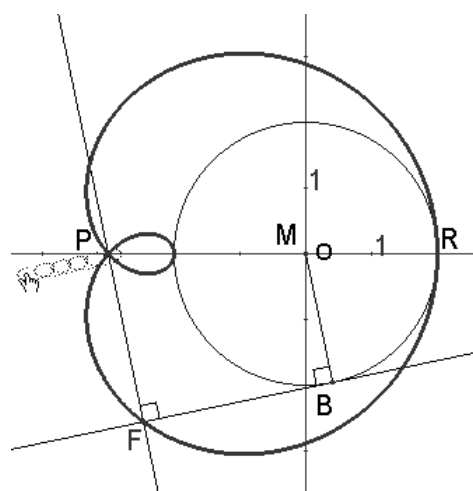

Fig. 2.2:

Variation of $|PM|$ values

The resulting locus is Pascal’s limaçon, and we can change its shape and position by varying the parameter values for $|PM|$ (Figs. 2.2 & 2.3) and for $|MR| = r$ (Fig. 2.4; there must be a gap in the animated graph for $r = 0$).

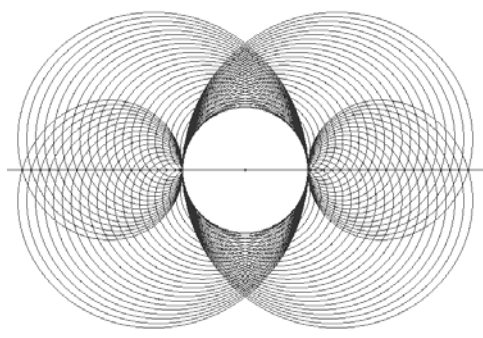

Fig. 2.3: Animation of

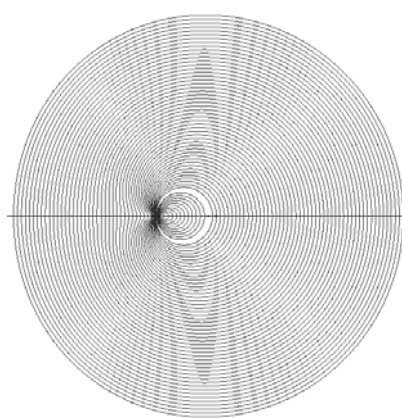

Fig. 2.4: Animation of

Pascal's limaçon for $|PM|$

Pascal's limaçon for r

In Cabri II+ we are now going to embed the construction in a coordinate system such that M coincides with the coordinate origin and P is on the x -axis (Fig. 2.5). For this curve, we let the computer calculate the equation $P(x, y) = 0$ with respect to this coordinate system. The equation is of 4th degree and shows at y only even exponents in accordance with its symmetry property. In addition, we make a point test to convince ourselves of the correctness of the black box output.

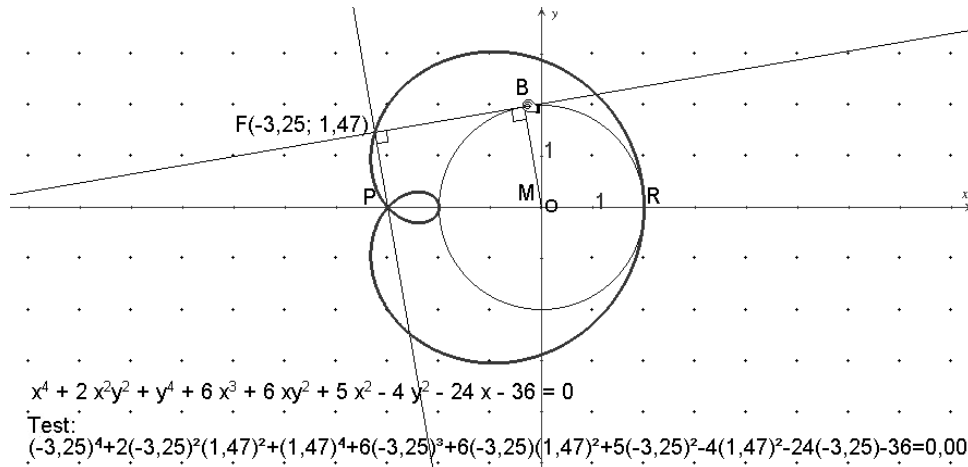

Fig. 2.5: Embedding Pascal's limaçon and equation testing

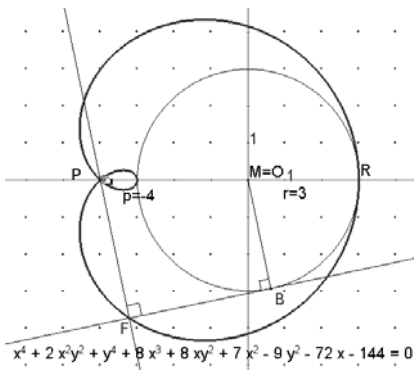

Fig. 2.6

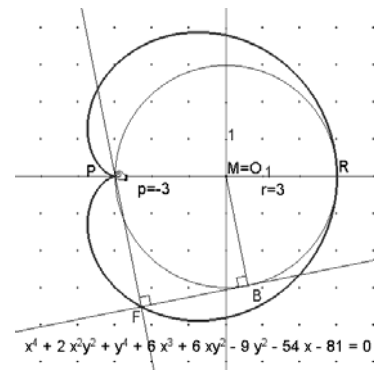

Fig. 2.7

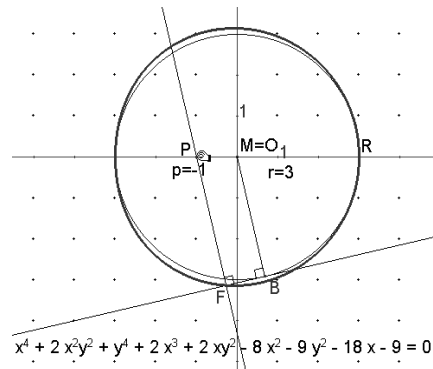
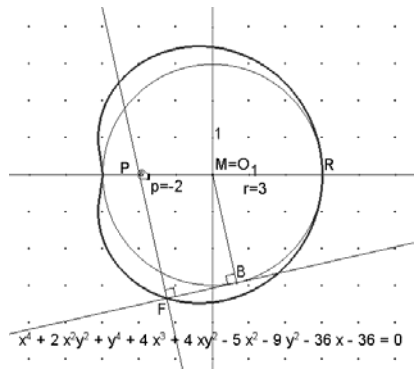

Fig. 2.8

Fig. 2.9

Investigating the dependencies of the coefficients from construction parameters

We can see that the partial expression $x^4 + 2x^2y^2 + y^4 = (x^2 + y^2)^2$ does not depend on the parameters p and r . Variation of the integral parameter values for p (e.g. as in Figs. 2.6 – 2.9; Fig. 2.7 shows the cardioid curve with its “heart-shaped” contour) and for r shows that each of the coefficients of x^3 and of xy^2 equals $2p$, that the coefficient of y^2 equals $-r^2$ and – with some intuition in arithmetics – that the coefficient of x equals $2pr^2$ and that the constant summand equals $-(pr)^2$. Tabulation may be helpful if this is not obvious at once. Of course one immediately tests the suspected dependences by variation of the parameter values of p and r . For example, the coefficient of x^2 can be found with the aid of the table below, which shows that the coefficients (e.g. for $r = 3$) create an arithmetic sequence of 2nd degree. With fixed r the coefficient of x^2 is a quadratic form $c_2p^2 + c_1p + c_0$.

$r = 3$	p	-1	-2	-3	-4	-5	...
	x^2	-8	-5	0	7	16	...
		+3	+5	+7	+9	...	

This means that c_2, c_1, c_0 can be derived from the following system of equations:

$$\begin{aligned} -8 &= c_2(-1)^2 + c_1(-1) + c_0 \\ -5 &= c_2(-2)^2 + c_1(-2) + c_0 \\ 0 &= c_2(-3)^2 + c_1(-3) + c_0 \end{aligned}$$

One finds $c_2 = 1$, $c_1 = 0$, $c_0 = -9$, i.e. $p^2 - 9 = p^2 - 3^2$ and presumably $p^2 - r^2$, which is verified experimentally. Finally, the following equation is obtained by the experimental-inductive method for Pascal’s limaçon with respect to the chosen coordinate system:

$$(x^2 + y^2)^2 + 2px^3 + 2pxy^2 + (p^2 - r^2)x - r^2y^2 + 2pr^2x - (pr)^2 = 0 \dots\dots (2.0)$$

The equation can now be verified also for non-integral coefficients in the same way as in Example 1, i.e. by implementing the equation for the curve in DERIVE and plotting the corresponding curve. For a mathematical verification of equation (2.0), we derive the parametric representation in accordance with the foot construction to get the corresponding equation by elimination of the running parameter. Figure 2.10 informs us that:

$$x_B = r \cdot \cos \beta, y_B = r \cdot \sin \beta \dots\dots\dots (2.1)$$

$$\text{tangent equation: } \frac{y - y_B}{x - x_B} = -\frac{\cos \beta}{\sin \beta} \dots\dots\dots (2.2)$$

$$\text{equation of the perpendicular: } \frac{y}{x - p} = \frac{\sin \beta}{\cos \beta} \dots\dots\dots (2.3)$$

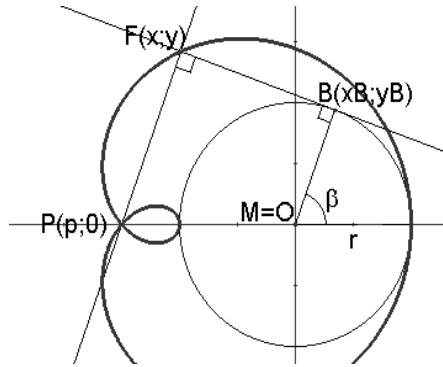

Fig. 2.10: Deriving the algebraic equation

After resolving of (2.2) or (2.3) to y and equating we obtain the x -coordinate of the foot of the perpendicular F :

$$x = p \cdot \sin^2 \beta + r \cdot \cos \beta \dots\dots\dots (2.4a)$$

and replacing x in (2.3) by (2.4a), the y -coordinate of F results in:

$$y = \sin \beta \cdot (r - p \cdot \cos \beta) \dots\dots\dots (2.4b)$$

Can we confirm that the parametric representation in (2.4) is that of the Pascal's limaçon? To verify this, we dynamically generate the corresponding curve using slider technique (Fig. 2.11). There are slides for the shape or position parameter p , r and there is a slide for the running parameter β . We are now able to observe the creation of the curve, either user-controlled or via animation, while the curve plotting functions of non dynamic mathematics software will show the curve only as a black box result.

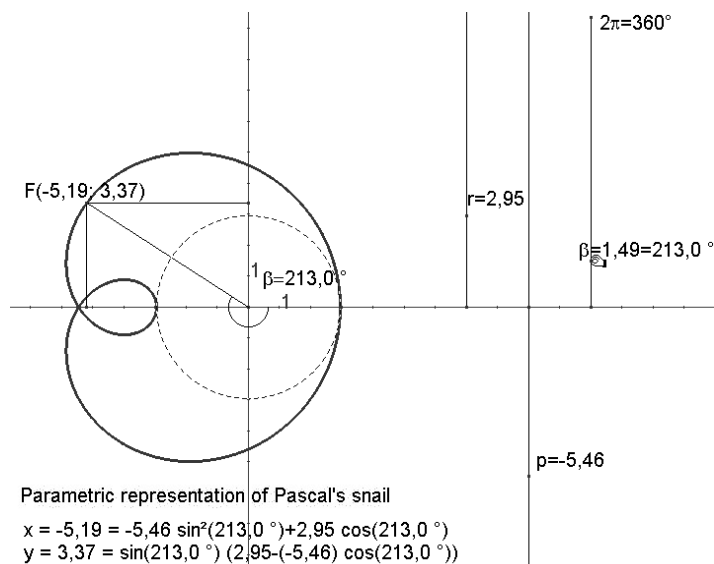

Fig. 2.11: Parametric representation of Pascal's limaçon

Elimination of the running parameter β is more difficult. Using a quadratic equation for $\cos \beta$, after some algebra supported by CAS, e.g. by DERIVE, obtain an equation that is equivalent to the equation presented in (2.0). Using the elimination command of the powerful tool MATHEMATICA, we will at once arrive at the desired result provided that we first express Sine by Cosine (Fig. 2.12).

$$\text{Eliminate}[\{x == p * (1 - (\text{Cos}(\beta))^2) + r * \text{Cos}(\beta), y == \sqrt{1 - (\text{Cos}(\beta))^2} * (r - p * \text{Cos}(\beta))\}, \beta]$$

$$-2 p x^3 + x^4 + p x (2 r^2 - 2 y^2) + x^2 (p^2 - r^2 + 2 y^2) == p^2 r^2 + r^2 y^2 - y^4$$

Fig. 2.12: Automatic elimination of the running parameter with MATHEMATICA

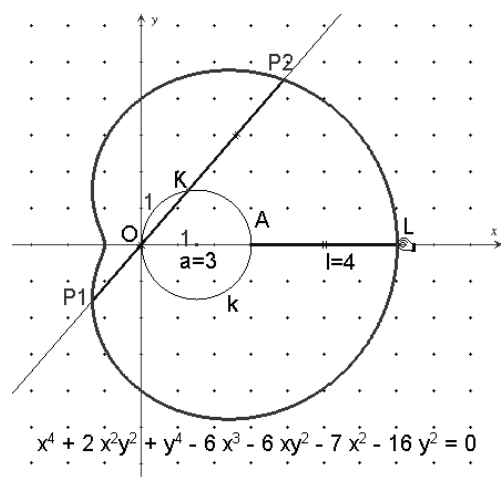

Fig. 2.13

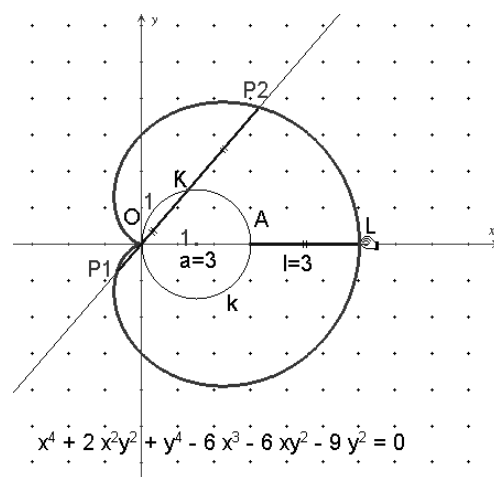

Fig. 2.14

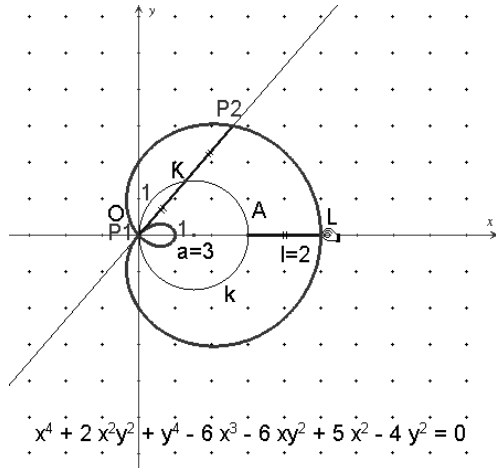

Fig. 2.15

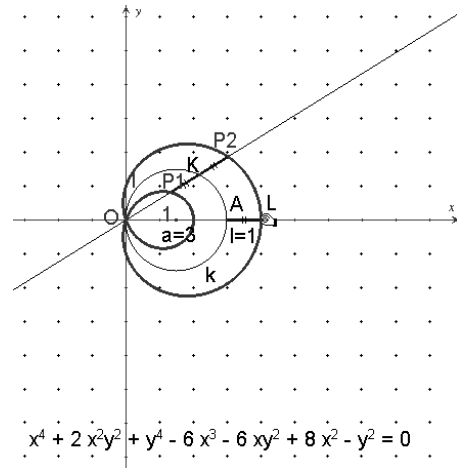

Fig.2.16

Pascal's limaçon as conchoid of the circle – investigating the coefficients

In the following, we discuss the corresponding treatment of Pascal's limaçon as a conchoid of the circle (Fig. 2.13). – The conchoid of a curve k with respect to a pole O consists of all points P to which the following applies: If K is a variable point on k and l is a fixed length, OKP will be located on a straight line, and $|OP| = |OK| + l$ or $|OP| = |OK| - l$. Construction parameters are the diameter of the circle a and the length l . Similar to the case of the curve constructed at the foot of the perpendicular, variation of integral parameter values (Figs. 2.13 – 2.16; variation of l) will give us the following dependences of the coefficients with respect to the coordinate system chosen:

$$(x^2 + y^2)^2 - 2ax^3 - 2axy^2 + (a^2 - l^2)x^2 - l^2y^2 = 0 \dots\dots\dots (2.5)$$

From the conchoidal construction we can easily read the polar coordinate representation (Fig. 2.17):

$$\rho = a \cdot \cos \varphi \pm l \dots\dots\dots (2.6)$$

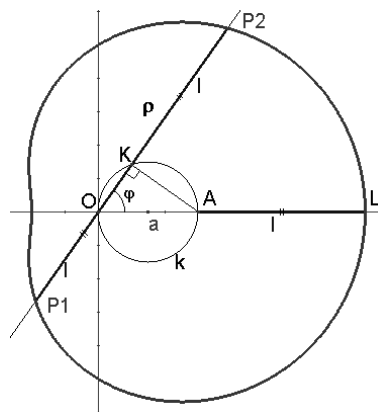

Fig. 2.17: Deriving the algebraic equation

From which we can dynamically generate the curve of Pascal's limaçon (Fig. 2.18). Using $\cos \varphi = \frac{x}{\rho}$ and $\rho = \sqrt{x^2 + y^2}$ from (2.6) easily follows the equation $(x^2 + y^2 - ax^2)^2 = \ell^2(x^2 + y^2)$, which is equivalent to (2.5) – on the contrary to the elimination of the running parameter at the parametric representation.

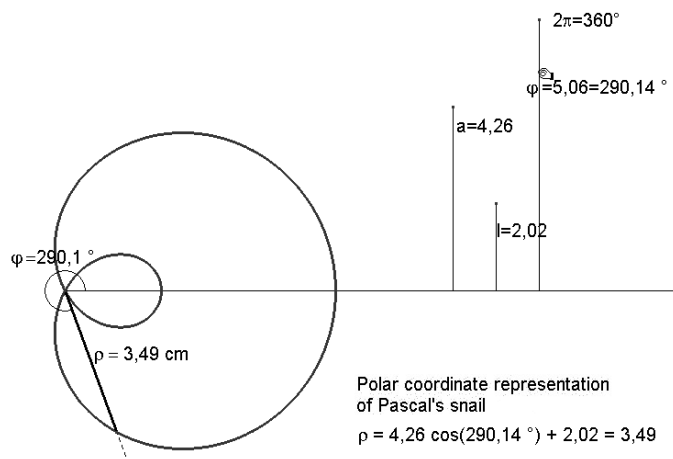

Fig. 2.18: Polar coordinate representation of Pascal's limaçon

Another interesting algebraic curve of the 4th degree is the conchoid of Nicomedes (Figs. 2.19 – 2.21), which is a conchoid of the line the corresponding treatment of which is left as an exercise.

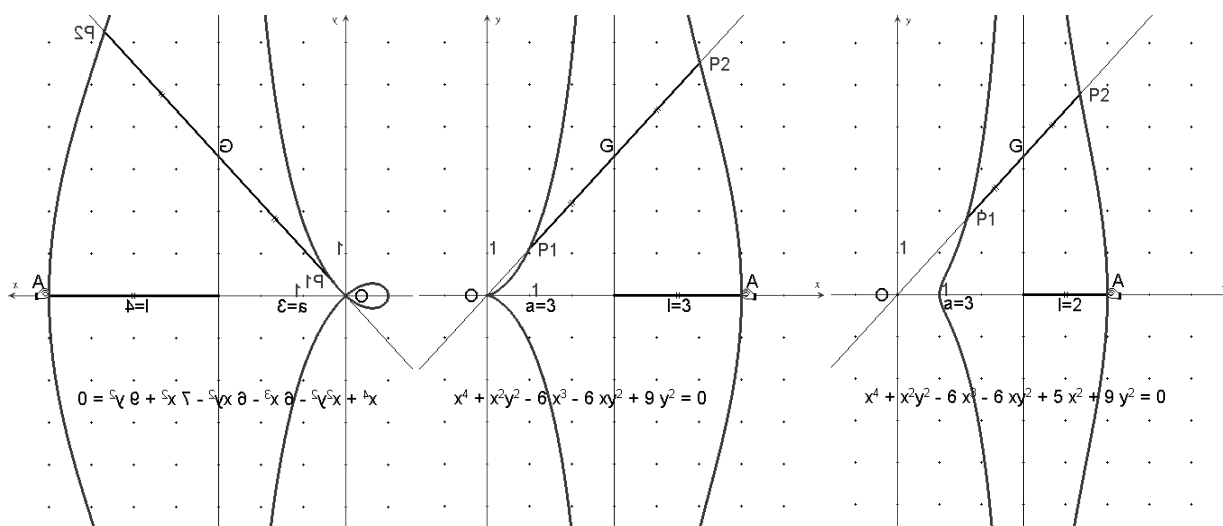

Fig. 2.19

Fig. 2.20

Fig. 2.21

Nicomedes Conchoid's construction and equation

Example 3 (Astroid)

As an example of the construction of algebraic curves as rolling curves we select the astroid which is generated by rolling of a circle onto a circle (circle cycloid) and whose points can be constructed as follows (Fig. 3.1):

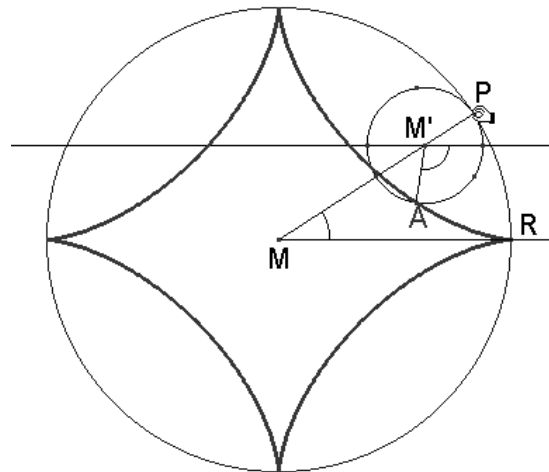

Fig. 3.1: An astroid's construction

- Circle with centre M through R ($r = |MR|$)
- Put a movable point P on this circle and connect it with M
- Laying off from P the distance $|MP|/4$ on MP in direction M and get M'
- Circle around M' with radius $|MP|/4$
- Parallel line to MR through M'
- Reflection of P with respect to this parallel, reflection of this reflected point with respect to MP and reflection of this radius with respect to the parallel results A , whose angle with respect to the parallel is three times as the counter oriented angle RMP (proof?).

What is the locus of A if P moves on the circle with centre M , e.g. if the circle with centre M' is rolling inside?

After embedding the construction in the coordinate system with M as coordinate origin Cabri II+ indicates the algebraic equation of the astroid, which is of 6th degree and in which all exponents of x and y must be even, corresponding to the symmetry of this locus (Fig. 3.2).

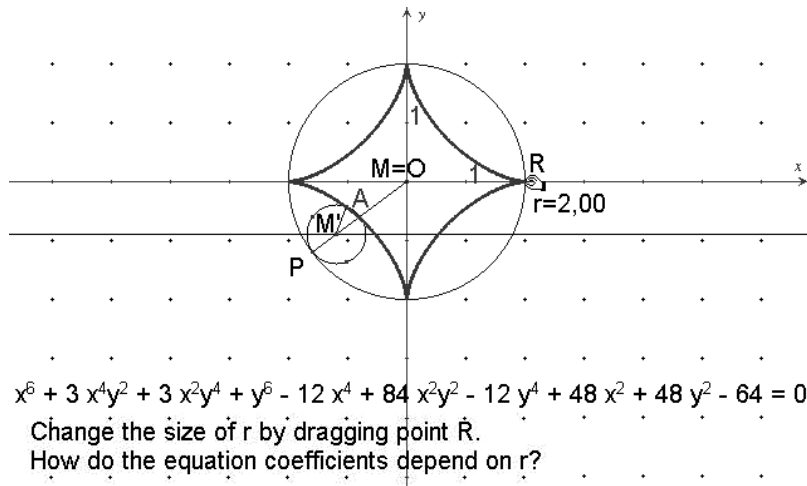

Fig. 3.2: Astroid's embedding and investigating coefficients

By varying the size of the construction parameter r by dragging of R (Fig. 3.2) we find out that the expressions of degree 6 are independent of r and can be summarised in $(x^2 + y^2)^3$, that x^4 and y^4 have the coefficient $-3r^2$, x^2y^2 has the coefficient $3r^2 \cdot 7$, x^2 and y^2 have the coefficient $3r^4$, and, last but not least, that the constant summand equals $-r^6$. The algebraic equation in x and y can therefore be written as

$$(x^2 + y^2)^3 - 3r^2(x^4 - 7x^2y^2 + y^4) + r^4(3x^2 + 3y^2 - r^2) = 0 \quad \dots\dots\dots (3.0)$$

We verify this equation by drawing the parameter representation of the astroid and eliminating the running parameter. According to the curve construction it is valid (Fig. 3.3):

$$r' = \frac{r}{4} \quad \text{and} \quad \varphi' = 3\varphi,$$

$$x = (r - r') \cos \varphi + r' \cos \varphi' \quad \text{and} \quad y = (r - r') \sin \varphi - r' \sin \varphi',$$

i.e. $x = \frac{r}{4} \cdot (3 \cos \varphi + \cos 3\varphi)$ and $y = \frac{r}{4} \cdot (3 \sin \varphi - \sin 3\varphi)$ and therefore follows with

$$\cos 3\varphi = 4 \cos^3 \varphi - 3 \cos \varphi \quad \text{and} \quad \sin 3\varphi = 3 \sin \varphi - 4 \sin^3 \varphi :$$

$$x = r \cdot \cos^3 \varphi \quad \text{and} \quad y = r \cdot \sin^3 \varphi \quad \dots\dots\dots (3.1)$$

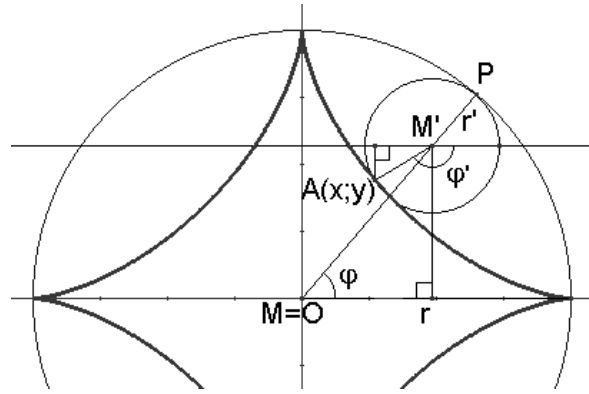

Fig. 3.3: Derivating the algebraic equation

This parametric representation is dynamically executed for controlling our result (Fig. 3.4). Varying the size of r within an interval we get an aesthetically pleasing animated graph (Fig. 3.5). We eliminate φ by extracting the third root and squaring the equations (3.1); addition leads to

$$x^{2/3} + y^{2/3} = r^{2/3} .$$

We use a computer algebra system, e.g. DERIVE (Fig. 3.6) to facilitate the transformation to an algebraic equation in x and y ; in doing so, it is decisive that line #6 should be substituted by line #1. The result in line #9 is equivalent to the inductively found result in (3.0).

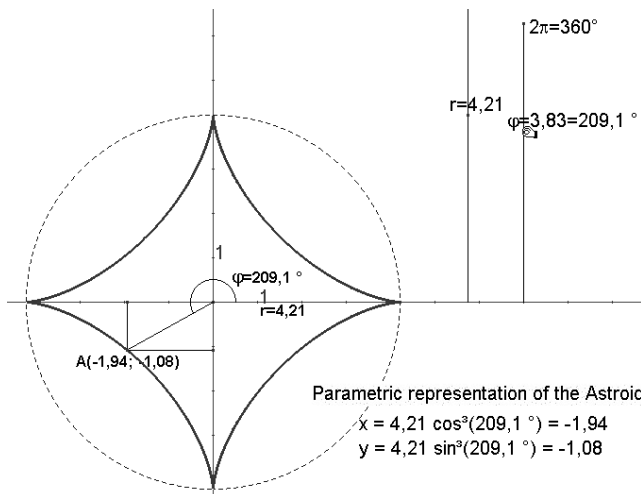

Fig. 3.4: Parametric representation of the astroid

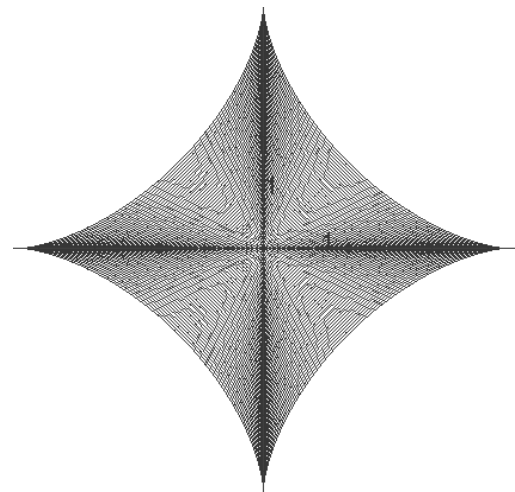

Fig. 3.5: Animation for parameter r

#1: $x^{2/3} + y^{2/3} = r^{2/3}$

#2: $(x^{2/3} + y^{2/3})^3 = r^2$

#3: $x^2 + 3 \cdot x^{4/3} \cdot y^{2/3} + 3 \cdot x^{2/3} \cdot y^{4/3} + y^2 = r^2$

#4: $(x^2 + 3 \cdot x^{4/3} \cdot y^{2/3} + 3 \cdot x^{2/3} \cdot y^{4/3} + y^2 = r^2) - r^2 = (3 \cdot x^{4/3} \cdot y^{2/3} + 3 \cdot x^{2/3} \cdot y^{4/3})$

#5: $x^2 + y^2 - r^2 = -3 \cdot x^{4/3} \cdot y^{2/3} - 3 \cdot x^{2/3} \cdot y^{4/3}$

#6: $x^2 + y^2 - r^2 = -3 \cdot x^{2/3} \cdot y^{2/3} \cdot (x^{2/3} + y^{2/3})$

#7: $x^2 + y^2 - r^2 = -3 \cdot x^{2/3} \cdot y^{2/3} \cdot r^{2/3}$

#8: $(x^2 + y^2 - r^2)^3 = -27 \cdot x^{2/3} \cdot y^{2/3} \cdot r^2$

#9: $(x^2 + y^2 - r^2)^3 = -27 \cdot r^2 \cdot x^{2/3} \cdot y^{2/3}$

Fig. 3.6: Deriving the algebraic equation with DERIVE

Example 4 (A ‘simple’ coupler curve)

Out of the numerous constructions of coupler curves we select the following:

- Circle around F_1 through K
- Put a movable point P on this circle with crank F_1P
- Reflect F_1 to O and get F_2
- Construct four bar linkage F_2F_1PQ (parallelogram) with coupler PQ
- Reflect Q to F_2P and get Q'
- Midpoint of PQ' : M .

What is the locus of M , if P circulates?

Figs. 4.1 – 4.3 show special cases of this curve. How do the coefficients of the algebraic equation for this curve depend on the constructive parameters $a = |F_1F_2|$ and $k = |OK|$? How can the equation in question be derived with the coefficients dependent on a and k ? (To be answered by the reader.)

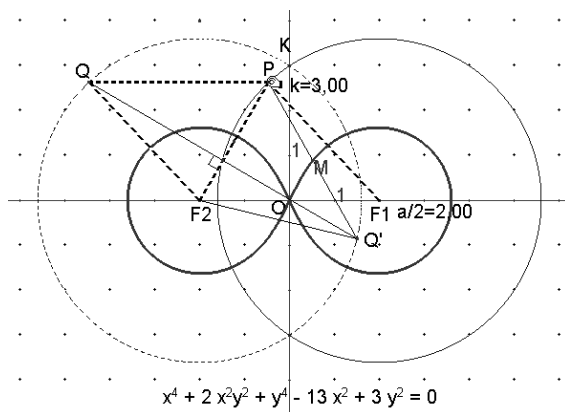

Fig. 4.1

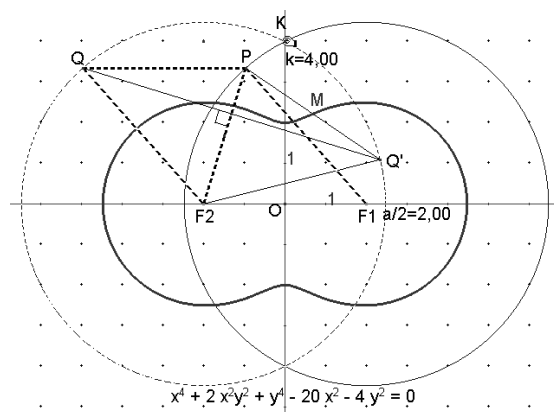

Fig. 4.2

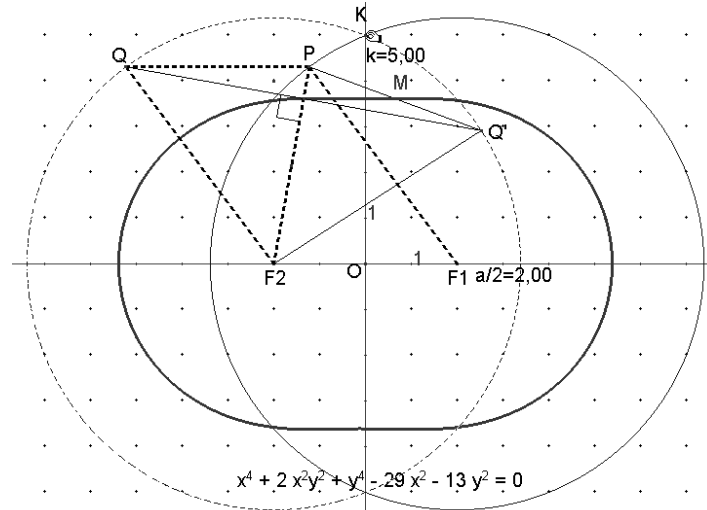

Fig. 4.3

Embedded coupler curve with its equation and variation of k values

4. Final notes

Note no. 1 (Limitedness of the method)

The method described here will fail if

- the algebraic curve is of a higher degree than 6, i.e. if the corresponding numeric algorithm is inaccurate or if the calculations are too complex
- the dependences of the coefficients on the integral construction parameters is not rational
- no integral parameterisation of the geometric construction of the algebraic curve can be expected, e.g. in the case of loci generated by specific points of the triangle if the vertices run on corresponding tracks. Fig. 5 shows an example of such a (point symmetric) locus generated by the intersection point of lines through the side midpoints which are parallel to the angle bisectors of right triangle ABC , if C is circulating.

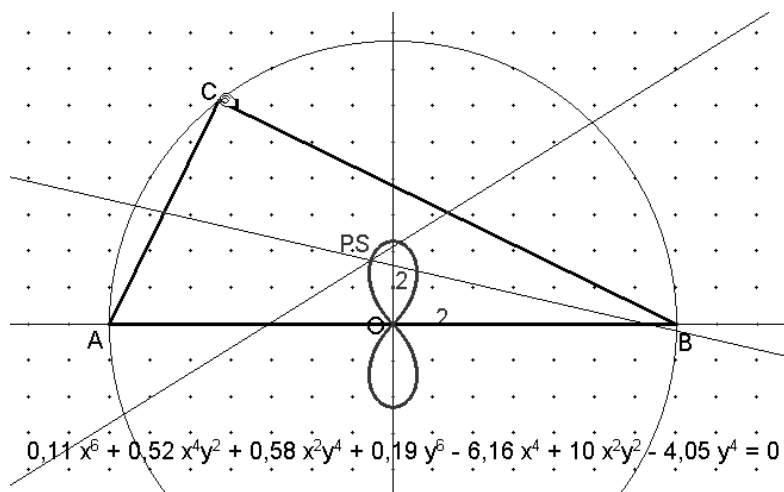

Fig. 5: An algebraic curve with non-rational parameterisation

Note no. 2 (Unsolved problems?)

In connection with the processing method which has been developed and applied in this paper the following problems appear:

- Among the algebraic curves generated with compass and ruler or with conic sections, how can we characterise those with equation coefficients which are integer rational functions of their integral construction parameters?
- Among the classical algebraic curves, there are no curves of degree 5 or 7. Is this due to the fact that algebraic curves of greater prime number degree than 3, which are zero-sets of irreducible polynomials, cannot be generated with compass and ruler or by means of conic sections?
- In the case of algebraic curves constructed with compass and ruler or with conic sections, their equations can be calculated by means of Groebner bases. What is the (algebraic) characterisation of such algebraic curves?

Note no. 3 (Advanced prototypic software tools)

- In 2002, Oliver Labs developed a new menu-controlled computer tool “SPICY” for treatment of algebraic curves and areas which runs under Linux. This tool has not been discussed here as it is not yet available in a commercial Windows version.
- Reinhard Oldenburg (2003) developed a tool named “Feli-X” which is still in the experimental and development stage. It is based on MATHEMATICA and consists of a dynamic geometry component which is compatible with the computer algebra component of MATHEMATICA. Feli-X is capable of calculating the exact equation of the constructed algebraic curve with respect to the absolute coordinate system. The reverse, i.e. not just plotting the curve belonging to an algebraic equation in x and y but generating an object that is referenceable in the sense of dynamic geometry, raises fundamental problems of “bi-directionality” between CAS and DGS.
- Eugenio Roanes-Lozano et al. (2003) have developed a similar tool “paramGeo” based on Maple or DERIVE to bridge Dynamic Geometry and Computer Algebra.

Note no. 4 (Further theoretical studies)

In his studies on Dynamic Geometry Systems, Gawlick (2001/2003) points out further aspects of geometric constructions and such of algebraic curves which go beyond our naive and classroom-oriented methodical and didactic approach.

References

- Gawlick, Th. (2001): Exploration reell algebraischer Kurven mit DGS und CAS. (Exploration of real algebraic curves with DGS and CAS). In: Elschenbroich, H.-J. et al.: Zeichnung – Figur – Zugfigur. Mathematische und didaktische Aspekte dynamischer Geometrie. Hildesheim: Franzbecker, p. 69 – 76
- Gawlick, Th. (2003): Über die Mächtigkeit dynamischer Konstruktionen mit verschiedenen Werkzeugen. (About the powerfulness of dynamic constructions with different tools). Bielefeld: IDM, Occasional Paper 185 (www.uni-bielefeld.de/idm/publikationen/occpap.html)
- Labs, O. (2002): SPICY – Mehr als dynamische Geometrie mit Hilfe von Computeralgebra. (SPICY – more than dynamic geometry with help of computer algebra). Vortrag auf der Fachtagung „Computeralgebra in Lehre, Ausbildung und Weiterbildung III“, 2.– 5. April 2002, Kloster Schöntal (www.oliverlabs.net/spicy)
- Oldenburg, R. (2003): Feli-X: Ein Prototyp zur Integration von CAS und DGS. (Feli-X: A prototype for integration of CAS and DGS). In: Bender, P. et al.: Lehr- und Lernprogramme für den Mathematikunterricht. Berichte über die 20. Arbeitstagung des Arbeitskreises “Mathematikunterricht und Informatik” in der GDM vom 27. bis zum 29. September 2002 in Soest, p. 123 – 132
- Roanes-Lozano, E. and Roanes-Maías, E., Villar-Mena, M. (2003): A Bridge Between Dynamic Geometry and Computer Algebra. In: Mathematical and Computer Modelling 37/9 – 10, p. 1005 – 1088
- Schumann, H. (1991): Schulgeometrisches Konstruieren mit dem Computer. (School geometric construction with the computer). Stuttgart: Metzler und Teubner (available in the Archiv of www.math-schumann.de)
- Schumann, H.; Green, D. (1994): Discovering Geometry with a Computer. Bromley/Kent: Chartwell-Bratt
- Schumann, H. (2001): Die Behandlung von Funktionen einer reellen Variablen mit Methoden der dynamischen Geometrie. (The treatment of functions of one real variables with methods of dynamic geometry). In: Elschenbroich, H.-J. et al.: Zeichnung – Figur – Zugfigur. Mathematische und didaktische Aspekte Dynamischer Geometrie. Hildesheim: Franzbecker, p. 173 – 182
- Schupp, H.; Dabrock, H. (1995): Höhere Kurven – Situative, mathematische, historische und didaktische Aspekte. (Higher curves – situative, mathematical, historical and didactic aspects). Mannheim: BI Wissenschaftsverlag
- Weth, Th. (1993): Zum Verständnis des Kurvenbegriffs im Mathematikunterricht. (For the understanding of the curve concept in the mathematics lesson). Hildesheim: Franzbecker